

# MASTER STREAM NOZZLE FOR MONITOR

## MODEL - VARSHA-40



### TECHNICAL DATA

NOZZLE FLOW RANGE	400 TO 800 GPM (1500 TO 3030 LPM)
WATER INLET CONNECTION	Swivel female 3" BSP
MATERIAL OF CONSTRUCTION	Hard Anodized Aluminium / Bronze / Stainless Steel with SS internals
MAXIMUM SERVICE PRESSURE	12 Bar (175 PSI)
JET & FOG PATTERN	With Spinning teeth 120 degree angle
WEIGHT (Approx)	Aluminum Nozzle - 4.8Kg Bronze Nozzle - 9.2Kg Stainless Steel - 8.8Kg
APPROVAL	FM Approved with Aluminium & Bronze Material



### DESCRIPTION

VARSHA-40, is fixed gallonage master stream nozzle, designed for heavy-duty use on fixed monitors. The nozzle is factory set for required flow between 400 to 800 GPM. The flow can be changed in the field by replacing plunger or addition of spacer. The flow pattern easily changeable under flowing condition. Superior fog pattern with field changeable spinning teeth. Excellent for AFFF application when used with premixed water-foam solution.

The nozzle is available with three different material, hard coat anodized Aluminium or Bronze or Stainless Steel, all with SS internals.

The performance data shown in this catalogue is effective stream trajectory in stand still air condition. The maximum overall reach of last water drop is approximately 3-5% more than the effective stream performance data given. The effective stream decreases by about 10% when used as foam nozzle with premixed water foam solution. The jet stream may get effected considerably with tail or head wind.

### MAINTENANCE

The nozzle must be inspected regularly for possible damage or dirt around the moving parts. If any abnormal conditions are observed such as poor discharge, excessive wear, water leak, corrosion effect, damage etc., then nozzle must be taken out of service and repaired by qualified technician or replaced.

The debris trapped in the nozzle may effect the nozzle performance. To remove trapped debris, the water flow must be stopped and thereafter carefully unscrew

and remove the nozzle deflector. Clean the nozzle and reassemble. While re-assembling the nozzle or as a normal preventive maintenance, water proof lubricant must be used on seal and moving parts for smooth operation. The nozzle must be operated periodically under full flow straight stream and for fog pattern.

Under normal condition water must be flown through the nozzle periodically and dirt around exterior moving parts must be cleaned, allowing nozzle to operate properly.

The nozzle must be inspected prior to and after each use. Greasing the moving parts and 'O' ring is required periodically. Over a time the seals may need to be replaced.

The owner is responsible for maintenance of the nozzle in proper operating condition.

After use with foam, nozzle to be flushed with fresh water.

### CAUTION

A trained personnel for fire fighting, with appropriate guidance & training must use the product to reduce the risk or injury. The nozzle must be fixed to the monitor carefully. The mismatched or damaged threads may cause leakage or uncouple the nozzle during operation.

Application of water or foam on an electric appliance can cause serious injury by electrocution, as water is a conductor of electricity.

The water supply to the nozzle must be gradual. Sudden surge of water supply must be avoided. The monitor mounting must be supported properly to support the nozzle reaction force.

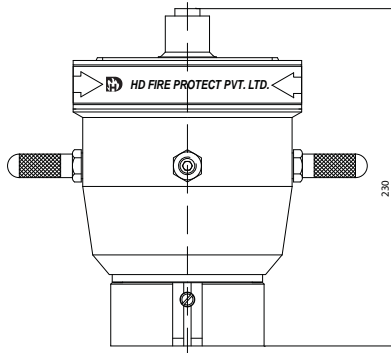

STREAM TRAJECTORY  
CROSS REF. IN % - JET REACH & HEIGHT

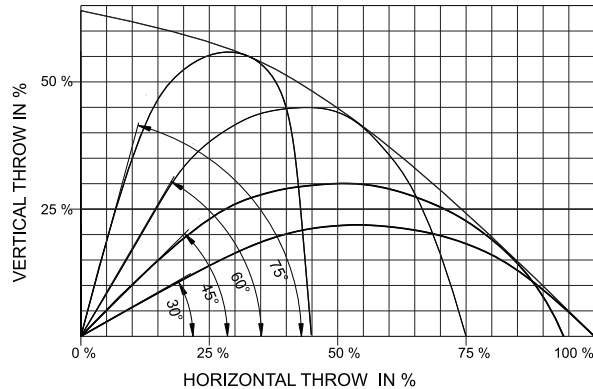

## PERFORMANCE DATA

SET FLOW RATE LPM (GPM)	NOZZLE PRESSURE KG/CM.SQ. (PSI)	ACTUAL FLOW RATE LPM (GPM)	STRAIGHT STREAM RANGE METERS (FEET)
1500 (400)	5.6 (80)	1342 (354)	54 (177)
	7.0 (100)	1500 (396)	58 (190)
	8.4 (120)	1643 (434)	60 (196)
1900 (500)	5.6 (80)	1700 (450)	57 (187)
	7.0 (100)	1900 (502)	61 (200)
	8.4 (120)	2080 (550)	63 (207)
2270 (600)	5.6 (80)	2030 (536)	58 (190)
	7.0 (100)	2270 (600)	62 (203)
	8.4 (120)	2485 (656)	64 (210)
2650 (700)	5.6 (80)	2370 (626)	61 (200)
	7.0 (100)	2650 (700)	63 (207)
	8.4 (120)	2903 (767)	64 (210)
3030 (800)	5.6 (80)	2710 (716)	63 (207)
	7.0 (100)	3030 (800)	65 (213)
	8.4 (120)	3319 (876)	66 (216)

PERFORMANCE DATA FOR WATER STREAM RANGE ARE BASED AT 30 DEG. NOZZLE ELEVATION IN STILL AIR CONDITION AND WITH HD MONITOR. WHEN USED WITH PREMIXED WATER FOAM SOLUTION THE FOAM REACH WILL DECREASE BY APPROXIMATELY 10% TO 15%.

### LIMITED WARRANTY

HD FIRE PROTECT PVT. LTD. hereby referred to as HD FIRE warrants to the original purchaser of the fire protection products manufactured by HD FIRE and to any other person to whom such equipment is transferred, that such products will be free from defect in material and workmanship under normal use and care, for two (2) years from the date of shipment by HD FIRE. Products or Components supplied or used by HD FIRE, but manufactured by others, are warranted only to the extent of the manufacturer's warranty. No warranty is given for product or components which have been subject to misuse, improper installation, corrosion, unauthorized repair, alteration or un-maintained. HD FIRE shall not be responsible for system design errors or improper installation or inaccurate or incomplete information supplied by buyer or buyer's representatives. HD FIRE will repair or replace defective material free of charge, which is returned to our factory, transportation charge prepaid, provided after our inspection the material is found to have been defective at the time of initial shipment from our works. HD FIRE shall not be liable for any incidental or consequential loss, damage or expense arising directly or indirectly from the use of the product including damages for injury to person, damages to property and penalties resulting from any products and components manufactured by HD FIRE. HD FIRE shall not be liable for any damages or labour charges or expense in making repair or adjustment to the product. HD FIRE shall not be liable for any damages or charges sustained in the adaptation or use of its engineering data & services. In no event shall HD Fire's product liability exceed an amount equal to the sale price. The foregoing warranty is exclusive and in lieu of all other warranties and representation whether expressed, implied, oral or written, including but not limited to, any implied warranties or merchantability or fitness for a particular purpose. All such other warranties and representations are hereby cancelled.

### NOTICE :

The equipment presented in this bulletin is to be installed in accordance with the latest publication standards of NFPA or other similar organisations and also with the provision of government codes or ordinances wherever applicable. The information provided by us are to the best of our knowledge and belief, and are general guidelines only. Site handling and installation control is beyond our reach. Hence we give no guarantee for result and take no liability for damages, loss or penalties whatsoever, resulting from our suggestion, information, recommendation or damages due to our product. Product development is a continuous programme of HD FIRE PROTECT PVT. LTD. and hence the right to modify any specification without prior notice is reserved with the company.



**HD FIRE PROTECT PVT. LTD.**  
Protecting What Matters Most to You

C-3/6, THE NANDANVAN IND. ESTATE, L. B. S. MARG, THANE 400 604., INDIA.  
 • PHONES : + (91) 22 2583 5434 • 2582 6958 • 2582 6793  
 • FAX : + (91) 22 2581 2524 • 6796 9049  
 • EMAIL : info@hdfire.com WEBSITE : www.hdfire.com